



# USER MANUAL

## SA40

# Table of Contents

<b>1</b>	<b>INSTALLATION DIAGRAMS</b> .....	<b>6</b>
<b>2</b>	<b>WIRING</b> .....	<b>6</b>
<b>3</b>	<b>BASIC CONCEPTS</b> .....	<b>9</b>
3.1	DESCRIPTION OF KEYS .....	9
3.2	CARD CATEGORIES .....	9
3.3	USER CATEGORIES .....	10
3.4	WIRING DEFINITION .....	10
<b>4</b>	<b>OPERATIONS</b> .....	<b>10</b>
	<b>APPENDIX 1: FAQ</b> .....	<b>16</b>
	<b>APPENDIX 2: PACKING LIST</b> .....	<b>16</b>

# 1 Installation Diagrams

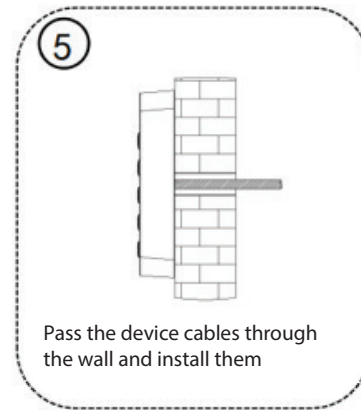
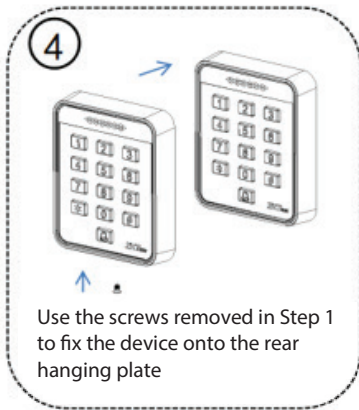
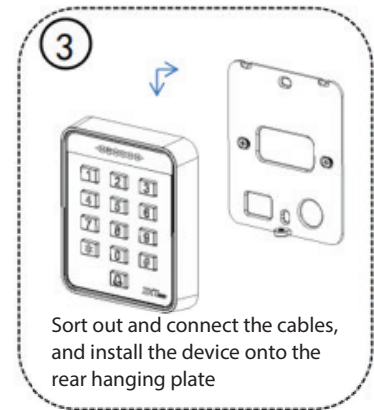
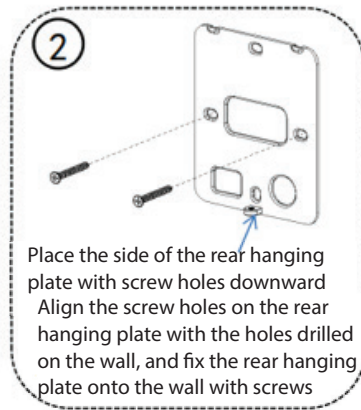
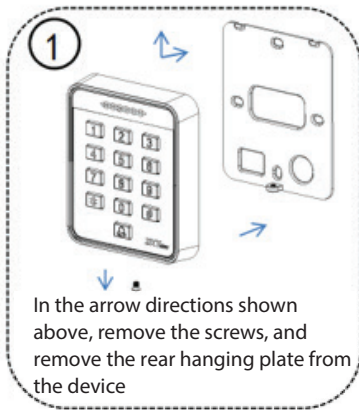

# 2 Wiring

**Warning:** Do not connect wires when the power is on!

Note:

- ① This device supports normally open (NO) and normally close (NC) locks which can be connected to different terminals for different functions.
- ② At the moment when the electric lock is turned on or off, the electric lock generates a self-induced electromotive force. To prevent the impact of the self-induced electromotive force on the access control system, it is necessary to connect an FR107 diode in parallel to the electric lock during wiring on the access control system to release the self-induced electromotive. The FR107 diode is randomly provided. Do not reverse its positive and negative poles.
- ③ If an extension cable needs to be connected between the all-in-one device and the controller, we recommend that you use a Category 6 or above unshielded network cable; otherwise, voltage drop may occur on the extension cable, resulting in an unstable card reading effect.

(1) **The device and the lock share the power supply**, as shown in Figure 1-1:

Note:  $U_{LOCK} = 12\text{ V}$ ,  $I \geq I_{DEVICE} + I_{LOCK}$ , and the lock is close to the device.

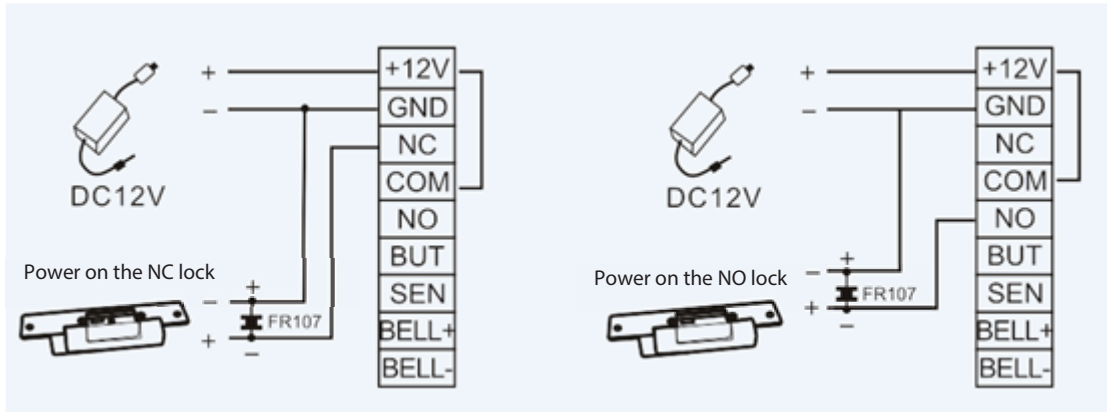

Figure 1-1

(2) **The device and the lock do not share the power supply**, as shown in Figure 1-2:

Note:

- ①  $U_{LOCK} = 12\text{ V}$ , and  $I < I_{DEVICE} + I_{LOCK}$
- ② Or  $U_{LOCK} \neq 12\text{ V}$
- ③ Or the lock is far from the device.

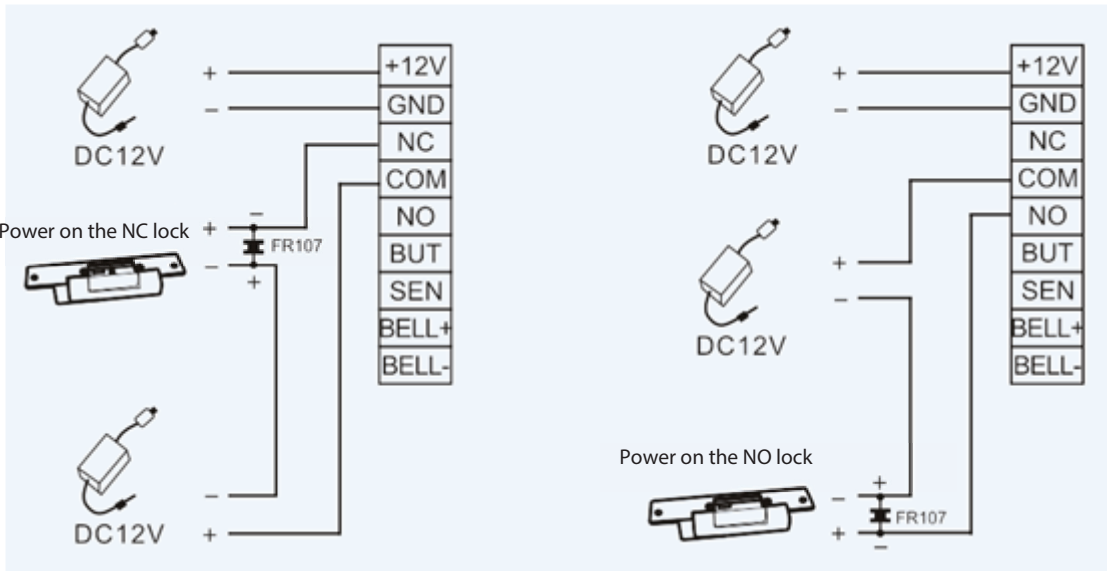

Figure 1-2

$I$  indicates the output current of the device power supply,  $U_{LOCK}$  indicates the operating voltage of the lock, and  $I_{LOCK}$  indicates the operating current of the lock.

(3) **Connect the power supply.**

The device uses a **DC 12V** power supply and external cables are connected directly to the main board. The operating current is **equal to or less than 200mA**, and the standby current is **equal to or less than 150mA**. The power supply can work after its positive and negative poles are connected to **+12V** and **GND** terminals respectively. **Do not reverse its positive and negative poles.**



(4) **Connect other devices**

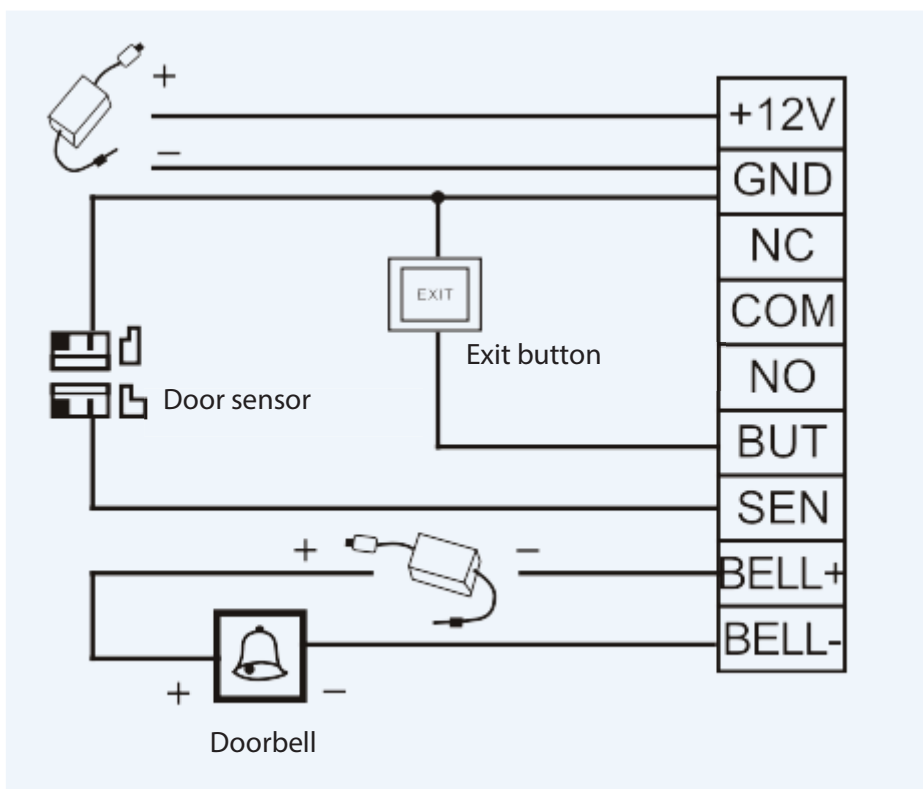

### 3 Basic Concepts

The following lists some basic concepts to help you quickly understand functions and operation methods of the all-in-one device.

#### 3.1 Description of Keys

Enter the administrator password or directly swipe the administrator card to enter the administrator settings mode.

Key	Description
0	Modify the administrator password or set the administrator card
1	Add a card-based user
2	Add a password-based user
3	Add a card-and-password user
4	Delete a user
5	Delete all users
6	Modify the user password
7	Modify the door opening delay time
8	Restore the default settings
9	Set the door opening password, add a card, or delete a card

#### 3.2 Card Categories

Category	Description
Installation card	<ul style="list-style-type: none"><li>(1) The installation card is the first card that is swiped after initialization.</li><li>(2) When the installation card is swiped once, it enters the card adding mode. If you swipe a user card, this card is added. You can swipe multiple cards consecutively.</li><li>(3) When the installation card is swiped twice, it enters the card deleting mode. If you swipe a user card, this card is deleted. You can swipe multiple cards consecutively.</li><li>(4) When the installation card is swiped for eight times, all users are cleared.</li><li>(5) In all modes, if no operation is performed within 10s, it exits the corresponding mode and enters the idle mode.</li></ul>
Administrator card	<p>In standby state, shortcut operation methods are as follows:</p> <ul style="list-style-type: none"><li>(1) When the administrator card is directly swiped once, the access control device enters the administrator mode.</li><li>(2) When the administrator card is directly swiped twice, the door sensor switches between the NO and NC modes.</li><li>(3) When the addition card is directly wiped, it enters the batch adding card-</li></ul>

	based users state. (4) When the deletion card is directly wiped, it enters the batch deleting card-based users state.
Addition card	This is used to add user cards.
Deletion card	This is used to delete user cards.

### 3.3 User Categories

Category	Description
Card-based user	This category of users can open the door only by swiping the card.
Password-based user	This category of users can open the door only by entering the password.
Card-and-password user	This category of users can open the door only by both swiping the card and entering the password.

### 3.4 Wiring Definition

Access Control Mode Wiring	
Red	DC 12V
Black	GND
Blue	NC (normally close)
Orange	COM (common)
Gray	NO (normally open)
Purple	SEN (door sensor)
Yellow	BUT (exit button)
Green	BELL+ (doorbell)
White	BELL- (doorbell)

## 4 Operations

When the operation is successful, the green indicator is on. When the operation failed, the blue indicator is on.

### 1. Restore Factory Settings

Before performing any operations on a new all-in-one access control device, you must restore its factory settings to initialize the device. To restore its factory settings, make a short circuit between pins 1 and 2, or between pins 2 and 3 of the 3-pin connector (next to the relay) on the device board, and then power on the device.

## 2. Initial Password

SN	Item	Description
1	Administrator password	The default initial password is 1234. The administrator password must contain 1-8 digits.
2	General door opening password	The default initial password is 8888. This password must contain 4-6 digits and it is a general password set by the administrator for opening the door.
3	User password	No default password is set. This password must contain 4-6 digits and it is a password customized by the user for opening the door.

## 3. Exit the Administrator State

Press \* to exit the administrator state. If no operation is performed within 10s, the system automatically exits the administrator state.

## 4. Set General Door Opening Password

Press \*#administrator password→9→enter a password of 4-6 digits#

**For example: \*#1234→9→123456#**

Note: The default administrator password is 1234 and the default general door opening password is 8888.

To delete the general door opening password, press \*#administrator password→9→0000#

**For example: \*#1234→9→0000#**

## 5. Set Administrator Card

Press \*#→administrator password→0→swipe the card

**For example: \*#1234→0→swipe the card**

Note: The system enters the administrator state after you swipe the administrator card.

## 6. Set Addition Card and Deletion Card

Press \*#administrator card→9→swipe the first card The card is added.

Swipe the second card The card is deleted.

**For example: \*#1234→9→swipe the first card The card is added.**

**Swipe the second card The card is deleted.**

## 7. Set Shortcut Operations

In standby state, you can use the administrator card, addition card, and deletion card to enter different function modes.



- 1) When the administrator card is directly swiped once, the access control device enters the administrator mode.
- 2) When the administrator card is swiped twice, the door sensor switches between the NO and NC modes.
- 3) When the addition card is directly swiped, it enters the batch adding user cards state.
- 4) When the deletion card is directly swiped, it enters the batch deleting user cards state.

### **8. Add a Card-based User**

Press \*#administrator password→1→swipe the card

**For example: \*#1234→1→swipe the card**

Note: You can swipe cards consecutively to add card-based users in batch and **press \* to exit the state.**

### **9. Add a Password-based User**

Press \*#administrator password→2→enter a user password of 4-6 digits#

**For example: \*#1234→2→123456#**

Note:

- 1) The user password must contain 4-6 digits.
- 2) After a password-based user is added, you can continue to enter the user password to consecutively add password-based users, and **press \* to exit the state.**

### **10. Add a Card-and-password User**

You can add a card-and-password user by using two methods.

- 1) Press \*#administrator password→3→enter a user password of 4-6 digits#→swipe the card

**For example: \*#1234→3→123456#→swipe the card**

- 2) Press \*#administrator password→3→swipe the card→enter a password of 4-6 digits#

**For example: \*#1234→3→swipe the card→123456#**

Note: After a card-and-password user is added, you can continue to enter the user password to consecutively add card-and-password users. You can either enter the password first and then swipe the card or swipe the card first and then enter the password to open the door. You can **press \* to exit the state.**

### **11. Delete a User**

You can delete a user by using three methods.

- 1) Press \*#administrator password→4→enter the user password# (You can consecutively enter the password to delete multiple users.)

**For example: \*#1234→4→123456# (You can consecutively enter the password to delete multiple users.)**

- 2) Press \*#administrator password→4→swipe the card (You can consecutively swipe the card to delete multiple users.)

**For example: \*#1234→4→swipe the card (You can consecutively swipe the card to delete multiple users.)**

- 3) Press \*#administrator password→4→enter the decimal card ID# (You can consecutively enter the decimal card IDs to delete multiple users.)

**For example: \*#1234→4→ 1234567890# (You can consecutively enter the decimal card IDs to delete multiple users. The actual digits of the card IDs shall prevail.)**

Note: You can perform operations consecutively in administrator state. When a card or password is deleted, the corresponding card-and-password user is also deleted automatically. You can **press \* to exit the state.**

## 12. Delete All Users

You can delete all users by using two methods.

- 1) Press \*#→administrator password→5→ #

**For example: \*→#→1234→5→ #**

- 2) In standby state, swipe the administrator card (to enter the administrator state), the deletion card, the addition card, and the deletion card in sequence.

**Note:** Only the card-based, password-based, or card-and-password user is deleted. The administration card, addition card, and deletion card are not deleted.

## 13. Modify Administrator Password

Press\*#→administrator password→0→new password→#→new password→#.

**For example: \*#→1234→0→1234567→ #→1234567→#**

Note: The administrator password must contain 1-8 digits. After the administrator password is set successfully, the system enters the administrator page.

If you forget the administrator password, you can swipe the administrator card to set a new one.

## 14. Modify User Password

You can modify the user password by using two methods.

- 1) Password-based users: Press \*#administrator password→6→old password#new password of 4-6 digits#

**For example: \*#→1234→6→123456→#→12345→#**

- 2) Card-and-password users: Press \*#administrator password→6→swipe the card→ new password of 4-6 digits#

**For example: \*#→1234→6→swipe the card→123456 #**

Note: You can perform operations consecutively in administrator state and **press \* to exit the state.**

### **15. Set Door Opening Delay Time**

Press \*#administrator password→7→1→enter the delay time#

**For example: \*#→1234→7→1→3s#**

Note: The door opening delay time is 0-60s. The default value is 3s and the maximum value is 60s.

### **16. Set Key Backlight**

Press\*#administrator password→7→5→0/1/2 (0: normally off; 1: normally on; 2: the backlight is off when you touch the key)

**For example: \*#→1234→7→5→0/1/2**

### **17. Set Indicator**

Press \*#administrator password→7→6→0/1 (0: off; 1: on)

**For example: \*#→1234→7→6→0/1**

### **18. Set Door Sensor Mode**

Press \*#administrator password→7→4→0/1 (0: NC; 1: NO)

**For example: \*#→1234→7→4→0/1**

### **19. Set Door Sensor Alarm Delay Time**

Press \*#administrator password→7→7→enter the alarm delay time#

**For example: \*#→1234→7→7→15#**

Note: The door sensor alarm delay time is 0-255s. The default value is 15s.

### **20. Set Main Alarm Switch**

In standby mode, you can enable or disable the door sensor alarm or the alarm for pressing a key by mistake through shortcut operations.

- 1) Enable the alarms: Directly swipe the addition card for three times to enable the door sensor alarm and the alarm for pressing a key by mistake.
- 2) Disable the alarms: Directly swipe the deletion card for three times to disable the door sensor alarm and the alarm for pressing a key by mistake.

### 21. Set Door Sensor Alarm Switch

Press \*#administrator password→7→2→0/1 (0: off; 1: on)

**For example: \*#→1234→7→2→0/1**

### 22. Set Switch for Alarm for Pressing a Key by Mistake

Press \*#administrator password→7→8→0/1 (0: off; 1: on)

**For example: \*#→1234→7→8→0/1**

Note:

- 1) The alarm for pressing a key by mistake is enabled by default. If you enter the administrator password incorrectly for five consecutive times, within 10s, you can only press keys (the buffer rings) but cannot swipe the card to open the door. 10s later, you can perform operations.
- 2) If the number of pressing a key by mistake is less than five times and no operation is performed 1 minute later, the number of pressing a key by mistake allowed is resumed to five times.

### 23. Restore Default Settings

You can restore the default settings of the access control device while retaining all the user data by using two methods.

- 1) Press \*#administrator password→8#→0#

**For example: \*#→1234→8#→0#**

- 2) In standby mode, the shortcut operation method is: directly swipe the deletion card, addition card, and deletion card in sequence. Then the device is initialized to the default parameter settings.

Note: After the device is initialized successfully, all settings are cleared but the user information is not cleared.

### Default Parameter Settings

General door opening password	The default initial value is 8888.
Door opening delay time	The value range is 1-60s. The default value is 3s.
Key backlight	The default value is normally on.

## Appendix 1: FAQ

FAQ	Solution
Failed to open the door by swiping the card	<ol style="list-style-type: none"><li>1. Check whether your card has been registered.</li><li>2. Check whether the wiring is correct.</li><li>3. Check whether the access control device is in the correct mode.</li></ol>
Failed to read the card	<ol style="list-style-type: none"><li>1. Check whether the card category is correct or whether the card is damaged.</li><li>2. Check whether the external card reader is too close to the access control device.</li></ol>

## Appendix 2: Packing List



Access control device & back plate

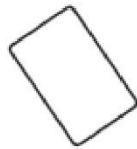

Card



FR107 diode



Screws for wall mounting



Rubber plugs



L-shaped hexagonal screwdriver



Tamper screw bolt

