



# **User Manual**

## **Swing Door Motor**

### **SDO-PK16**

---

## **WARNING TO THE INSTALLER AND USER**

- 1) CAUTION! For personal safety it is important to follow all the instructions carefully. Incorrect installation or misuse of the product may cause serious injury to people .
- 2) This product must be installed, debugged and maintained by professional and qualified personnel.
- 3) The power supply voltage must match the design requirements of this product and comply with electrical safety regulations.
- 4) This product was designed and manufactured strictly for the use indicated in this document. Any other usage not expressly indicated in this Document, may damage the product and/or be a source of danger.
- 5) The company is not responsible for losses caused by improper use .
- 6) Before carrying out any work on the product, turn off the Power supply.
- 7) This product must be equipped with an independent 6 A circuit breaker.
- 8) Do not make any alterations to the components of the product( Opener and Accessory).
- 9) Keep the instructions in a safe place for future reference.

## 1. Main Parts

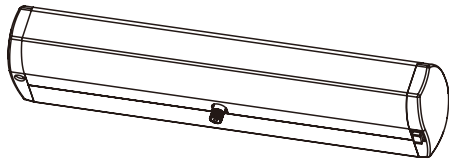

PK16, swing door opener

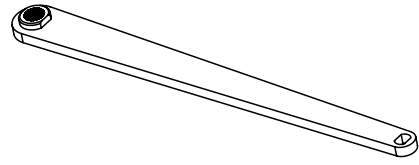

The main rod

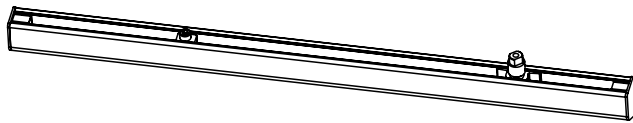

The pull rod (option)



transmitter



The push rod (option)



screws

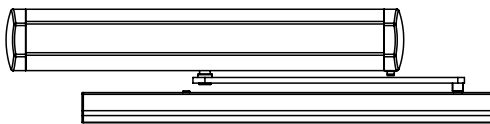

The opener with pull rod

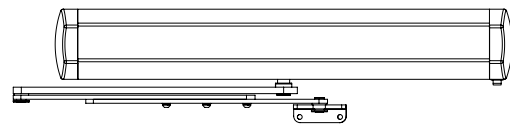

The opener with push rod

## 2. Dimensions

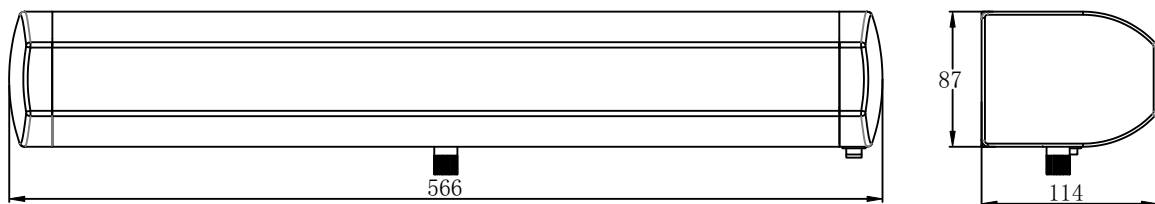

### 3. Technical Data

Power supply	AC220V±10% 50HZ
Power of motor	24VDC/40W
Rpm of motor	1600RPM
Open/close time	3-10S (adjustable)
Maximum opening angle	120°
Maximum door width	1200mm
Maximum door weight	120Kg
Working temperature	-20℃ ~ 50℃

### 4. Features

- \* Pull or push to activate the door opener operation.
- \* Automatic learning open-limit and close-limit when power on.
- \* Soft stop before open and close limits.
- \* Automatically Return when encountering resistance.
- \* Protection and access control equipment can be connected, such as radar, infrared sensor, card reader, electromagnetic lock, electric bolt lock, etc.
- \* With Fire alarm linkage interface.

### 5. Installation



---

## 5.1 Installation diagram

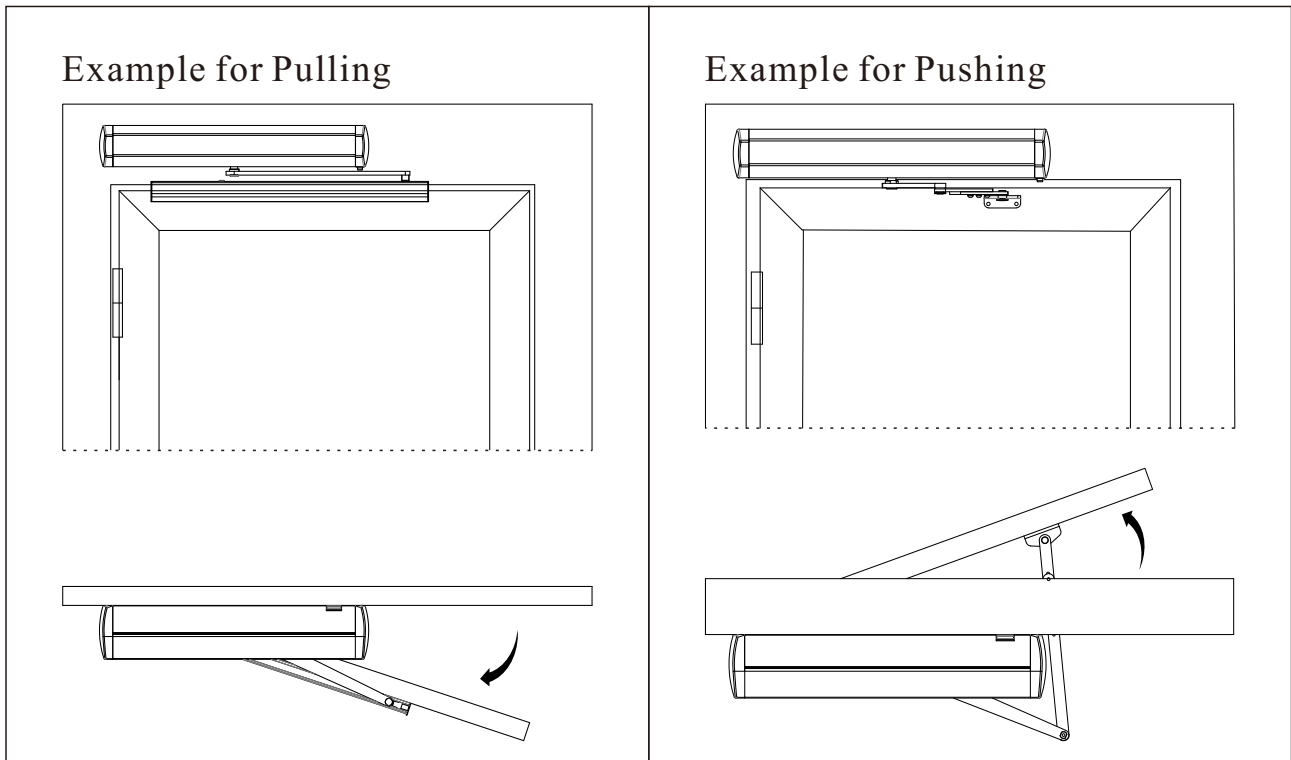

### Very Important Notice!

**Both the door frame and the door must be firm and strong.**

**Ensure the fixed points that the door opener installed on the door frame and the door are firm and reliable, and will not loosen during operation!**

## 5.2 Open the Cover before installation

Press one side of the cover to get it out of the slot, turn it over and take it out.

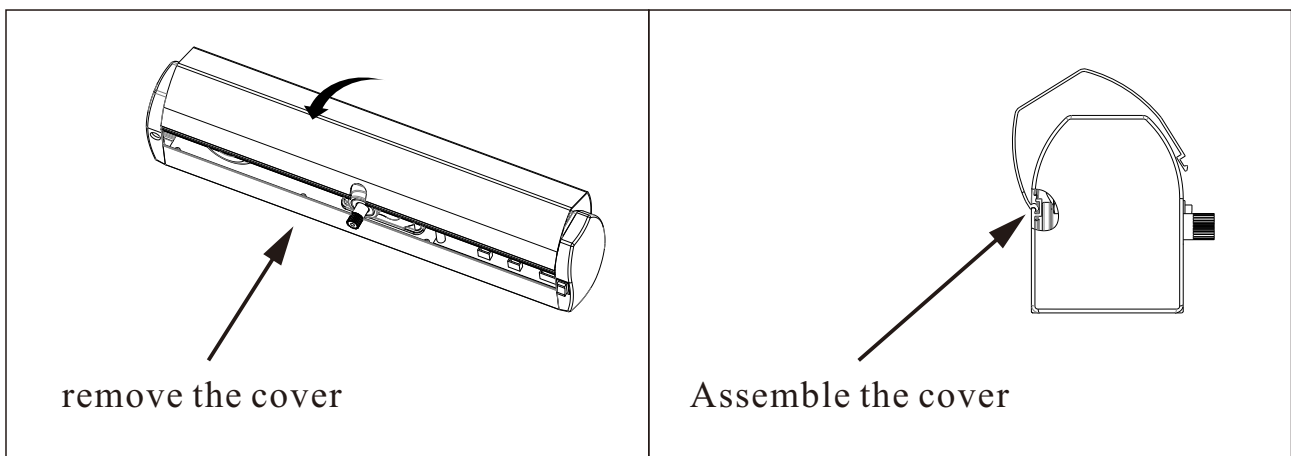

---

## 5.3 Installation steps of PULLING OPENER

### 5.3.1 Installation location and measurement

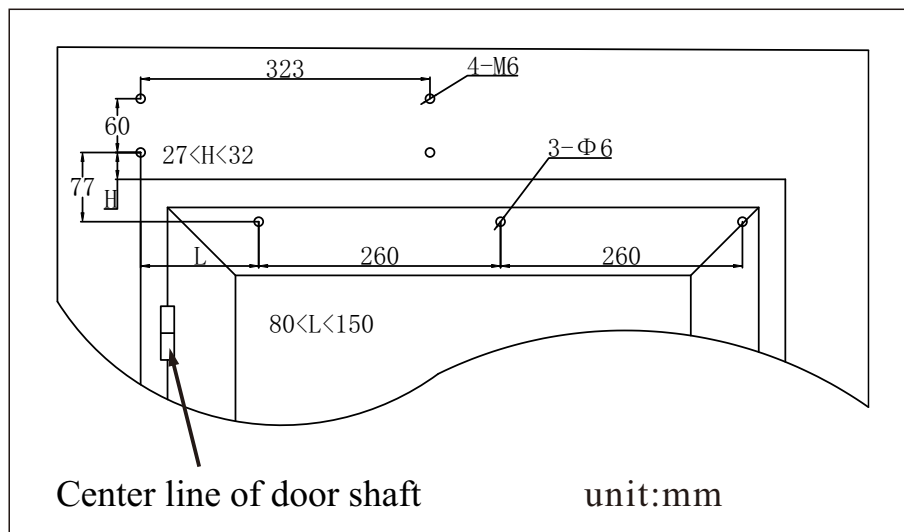

### 5.3.2 Installation of OPENER

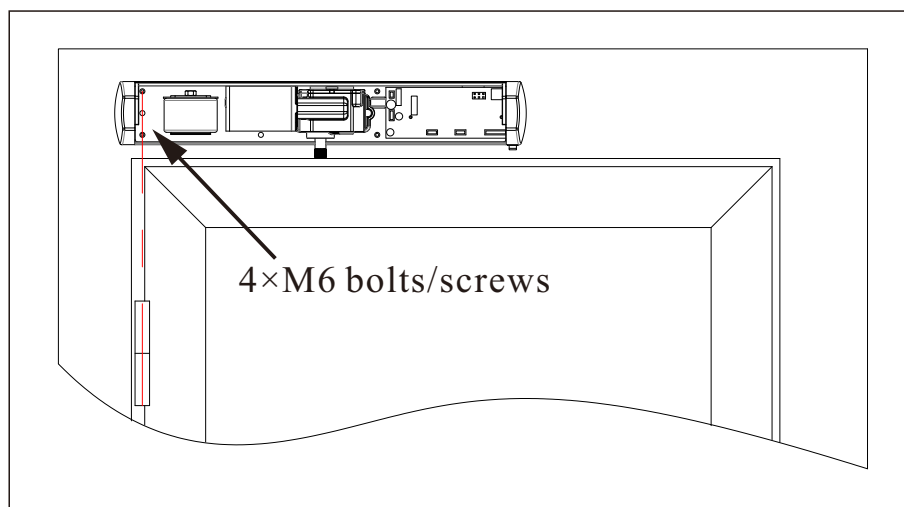

### 5.3.3 Installation of the MAIN ROD

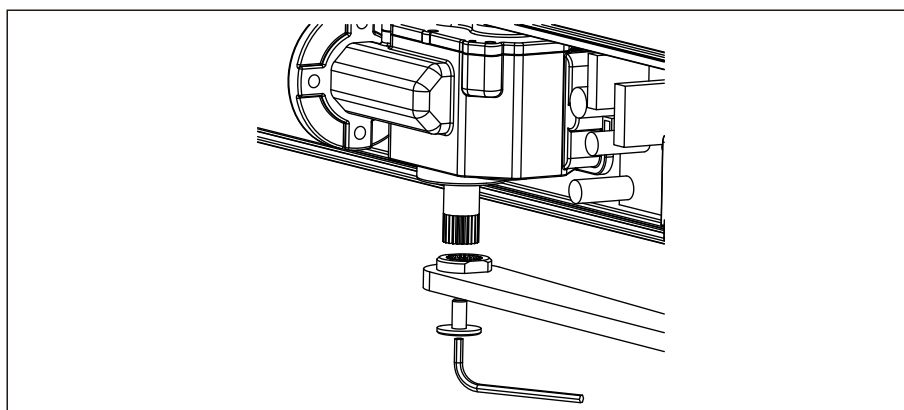

### 5.3.4 Installation of the PULL ROD

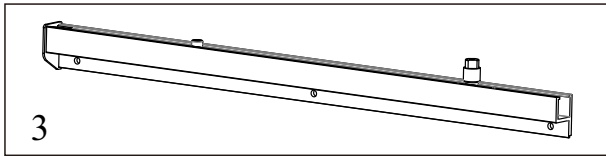
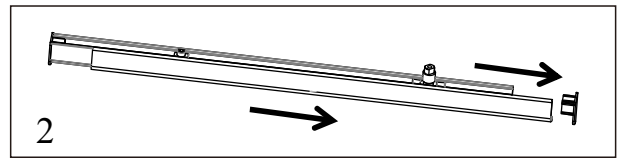

Note: The gap between the lower edge of the main rod from the upper edge of the door must be  $\geq 5$  mm to prevent interference with the door

4

First, use an Allen key to loosen the block screw. Then open the door completely, set the limit stopper about 5mm away from the slider.

5

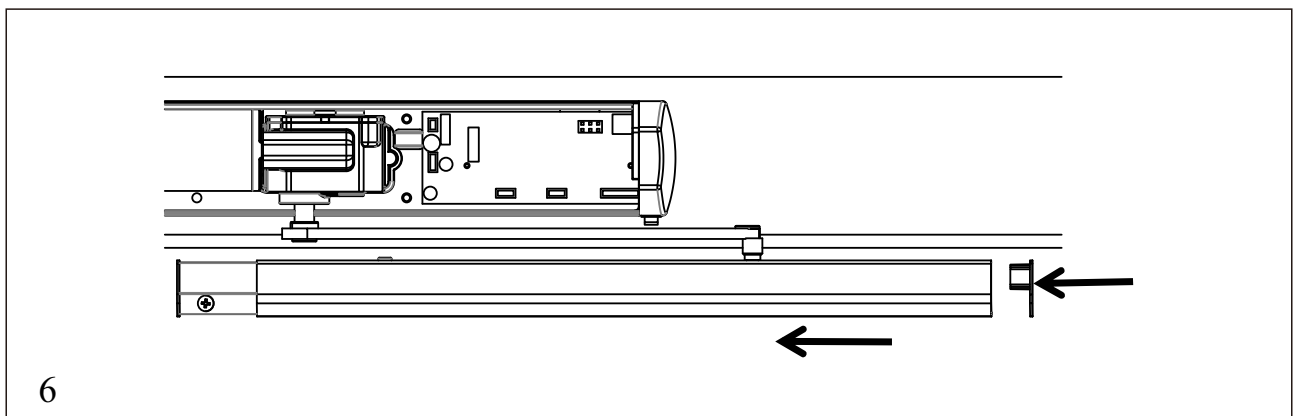

---

## 5.4 Installation steps of PULLING OPENER

### 5.4.1 Installation location and measurement

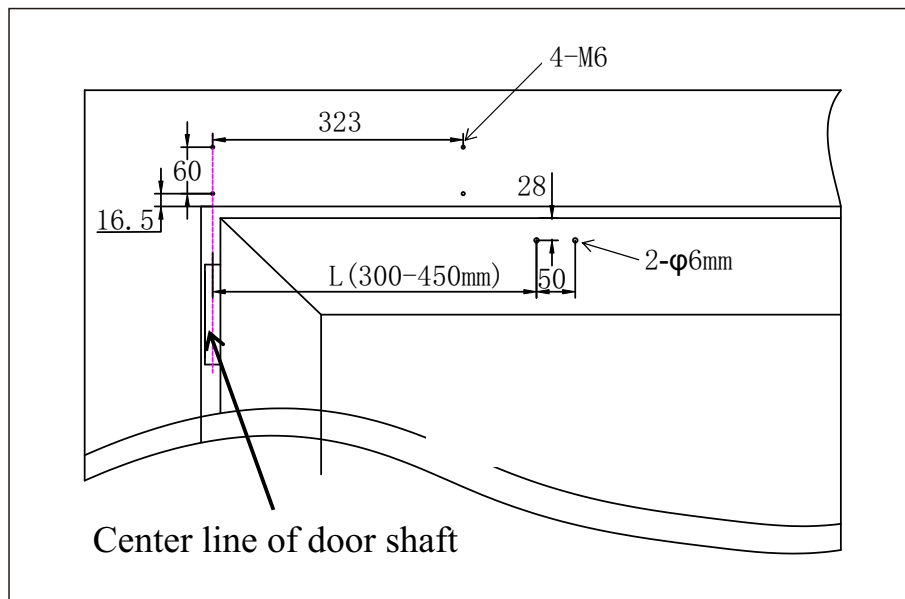

(Installation of OPENER and the MAIN ROD, refer to 5.3.3)

### 5.4.2 Installation of the PUSH ROD

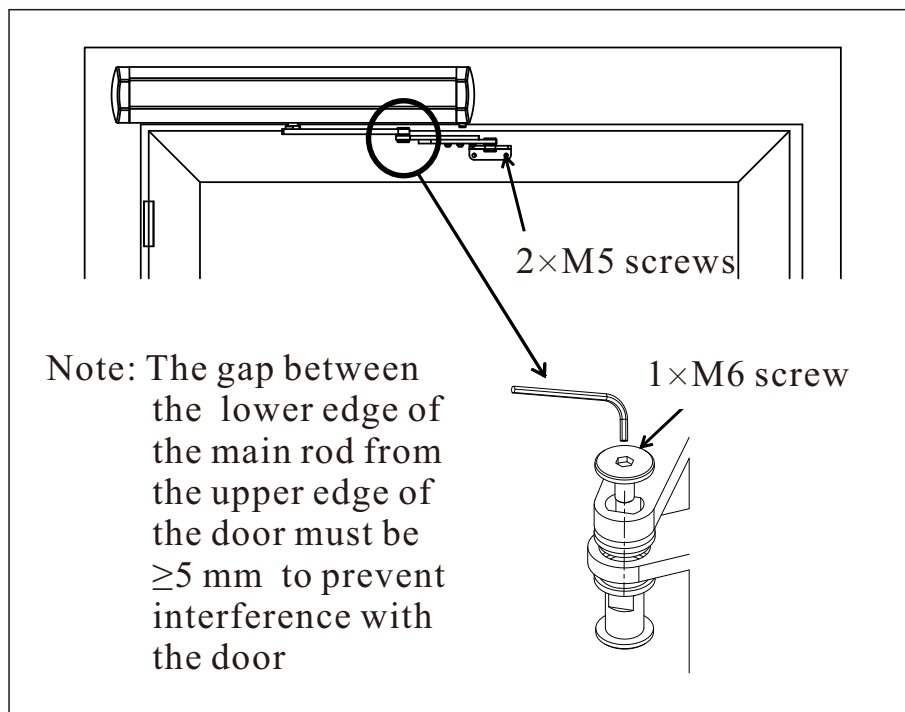



# 6.CONTROL BOARDS

## 6.1 Single door

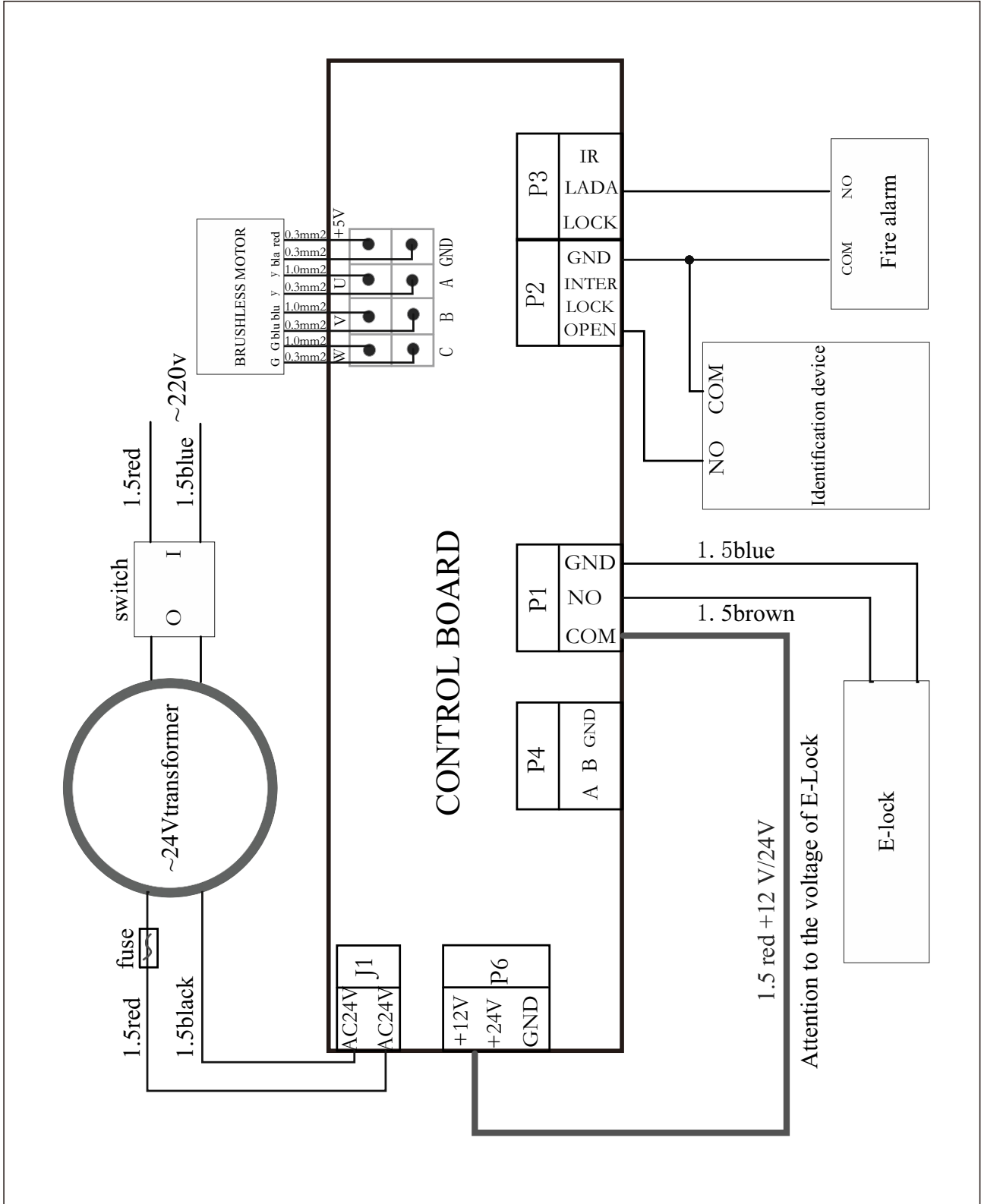

## 6.2 Dual-door

Notice:

Define the door that opens ahead but closes behind as the MASTER DOOR.

Define the door that opens behind but closes ahead as the SLAVE DOOR.

All signals are accessed by the MASTER and send out instructions. (Refer to 7.1 DIP switch settings for dual-door mode.)

The SLAVE needn't learn Transmitter. It acts following the MASTER.

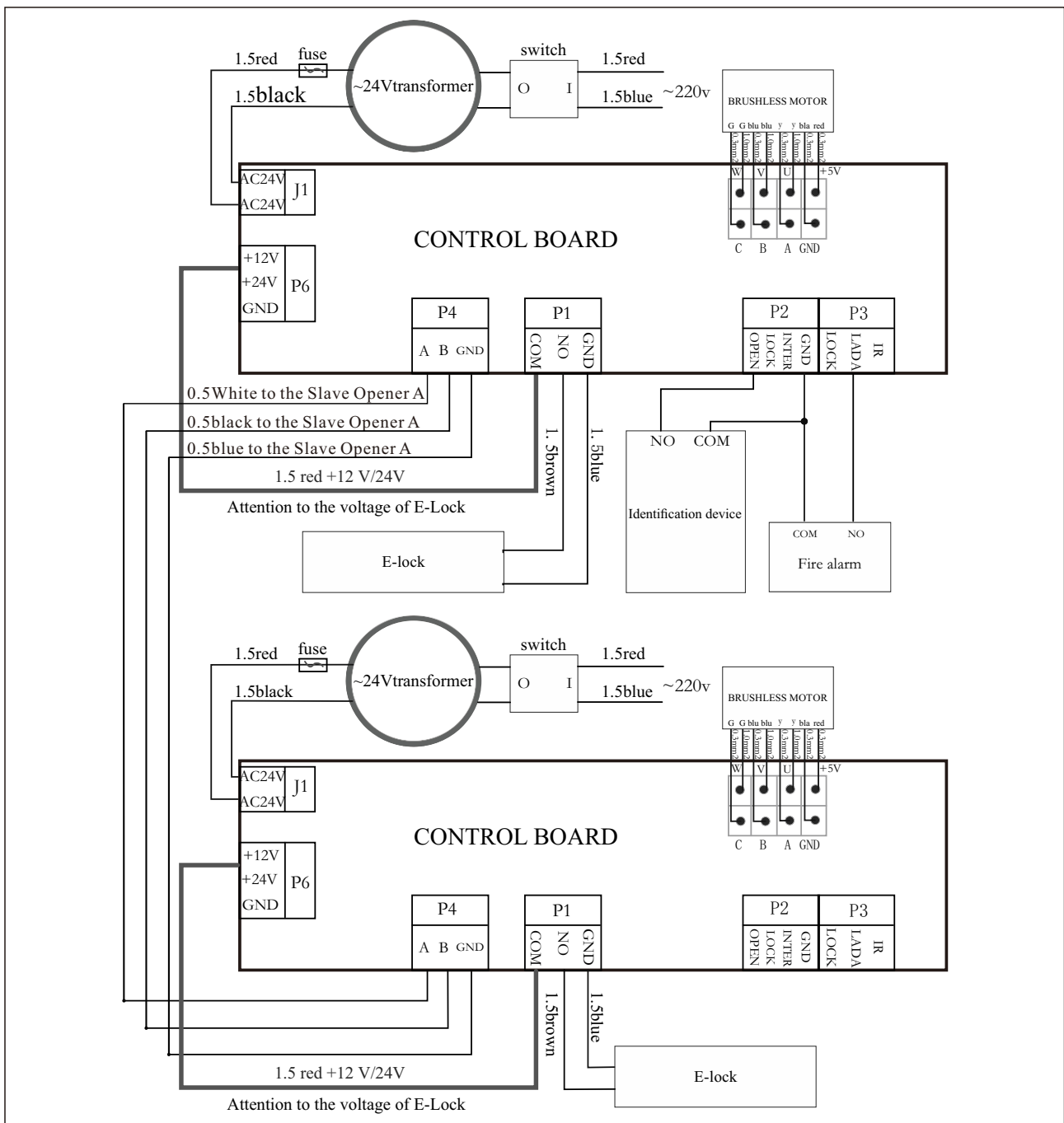

## 7. Dip switch, learning code and mode setting

### 7.1 Definition of Dipswitches and Transmitter

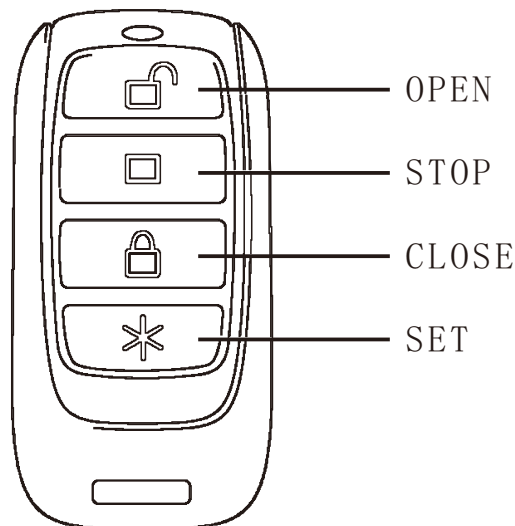
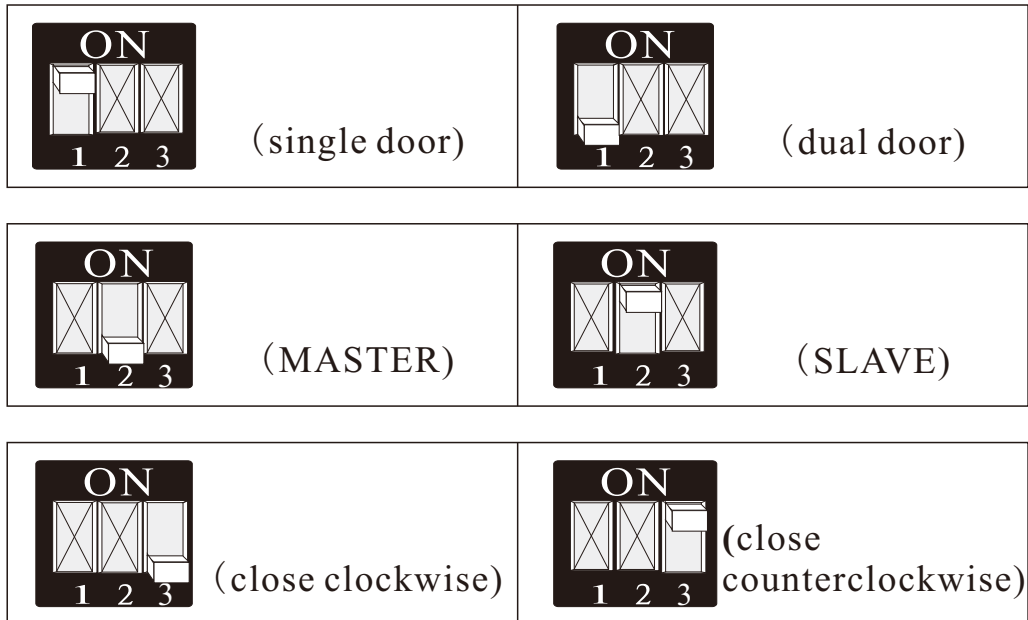

**Important:** There is only a "learn" button on the door opener control board. Before setting on the Transmitter, it must be coded.

For a dual-door, only the MASTER OPENER code Transmitter. All parameters be set on the Master.

---

## \* Functions of Buttons

### OPEN:

- ① Open the door.
- ② To be set to normally open mode after being pressed and hold for 3 seconds .
- ③ Increase parameter value during setting process.

### CLOSE:

- ① Close the door.
- ② Restore automatic close function after being pressed in normally open mode.
- ③ Decrease parameter value during setting process.

### STOP:

- ① Stop the running door.
- ② Exit from setting process.

### SET:

- ① Enter SETTING after being pressed and hold for 3 seconds.
- ② Switch menu when entering setting process.
- ③ Exit the setting process by keep pressing.

## **7.2 Limits self-learning**

**The Opener can be used only after the Limits Self-learning (setting) is finished.**

Close the doors completely before power on. After the display value of the digital tube has changed from 40 to 10, it means that the limits setting is completed.

If the door open after power-on, dial the dip-switch 3 to the opposite , then power off and power on again.

## **7.3 Transmitter's coding and Erasing**

### 7.3.1 Transmitter's code setting

Press "LEARN" button on the Control Board to the LED light on, then press the button which you choose on the transmitter till the LED flashes and goes out. Now, the transmitter is coded. Other transmitters can be coded as this way.

### 7.3.2 Erasing the transmitter's code

Press "LEARN" button on the Control Board and hold on to make the "LEARN LED" light on up to go out. Now, all transmitters which had been coded are cleared.

## 7.4 Parameters setting

### 7.4.1 Definitions

Menu code	range	Factory settngis	functions	description
P1	15-70	50	Open speed	The larger the value, the faster the speed
P2	15-70	40	Close speed	
P3	10-50	25	Open slow speed	
P4	10-50	20	Close slow speed	
P5	15-99	25	Open deceleration range	The larger the value, the larger the slow-moving range.
P6	15-99	25	Close deceleration range	
P7	5-99	05	Automatic closing time	The larger the value, the longer the door stays open.
P8	20-90	40	Maximum open angle	The larger the value, the larger the open angle.
P9	00-01	01	Mode of opening	00 push to open 01 with E-LOCK
H0	00-99	01	Start interval	Master opener and Slave Opener start interval
H1	10-99	40	Resistance sensitivity	The smaller the value, the higher the sensitivity.
H2	00-01	00	Vigorously close door mode	00 not enabled. 01 enabled. This function is activated when there is a brush edge between two doors
H3	1-10	01	Duration of vigorously closing	Unit:second
H4	0-25	05	strength	The larger the value, the greater the force.
H5	00-01	01	Remote control mode	00 Three buttons respectively control open, stop and close 01 one button control open, stop and close
H6	00-01	00	Infrared protector mode	00 normal open 01 normal close
E1	00-01	00	Hall sensor failure	Error code
E2	00-01	00	Run timeout failure	
E3	00-01	00	Door opening is blocked	
E4	00-01	00	Door closing is blocked	
E5	00-01	00	Abnormal voltage	

\* P9=00,PUSH TO OPEN. When the door be pushed at the angle  $>5^{\circ}$ , it will open automatic.

\* H2=00,the door will stop when it touches the door frame slightly. H2=01, when the door is close to the door frame the closing force is stronger.

\* H5=01,only one button works step by step,open-stop-close-stop-open...

---

## 7.4.2 Setting

Press the SET button on the Transmitter and hold till displaying P1 to enter Setting process. Refer to the following steps and the 6.3.1 Definitionstable for parameter setting.

After setting the parameters, keep pressing the SET or STOP to save and exit.

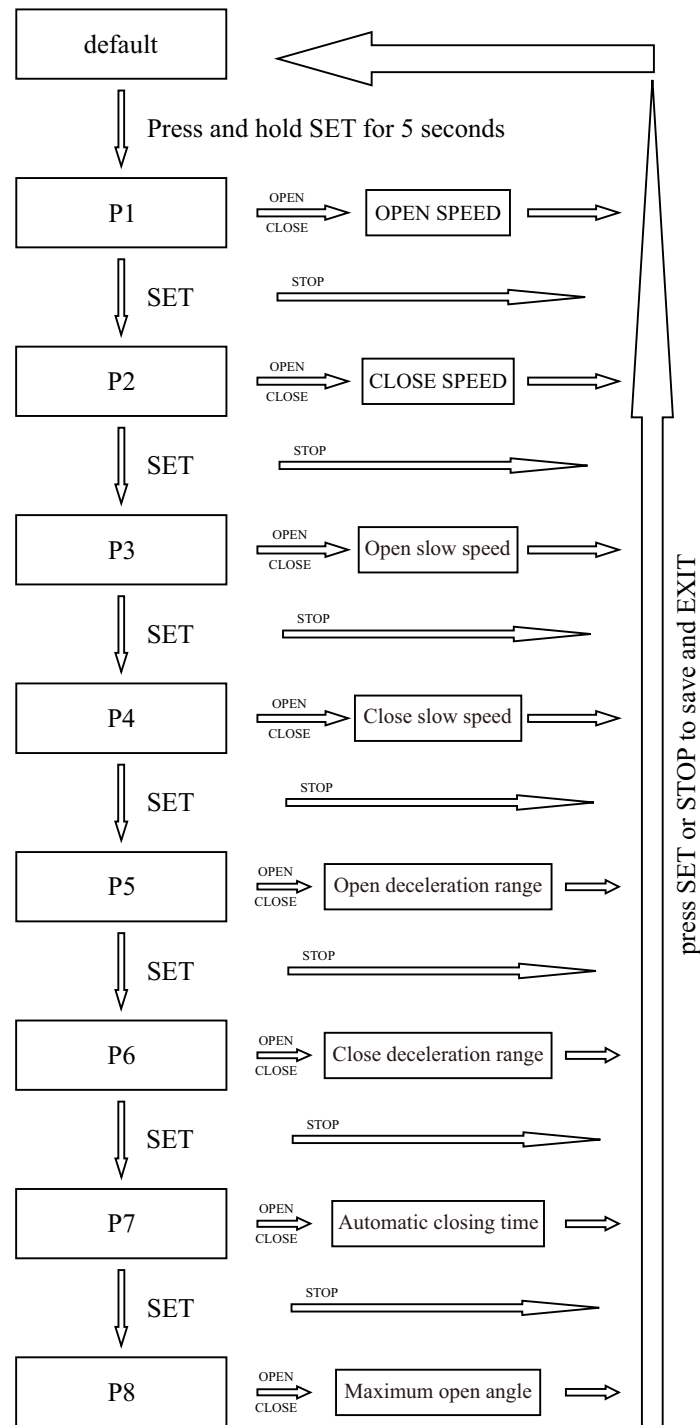

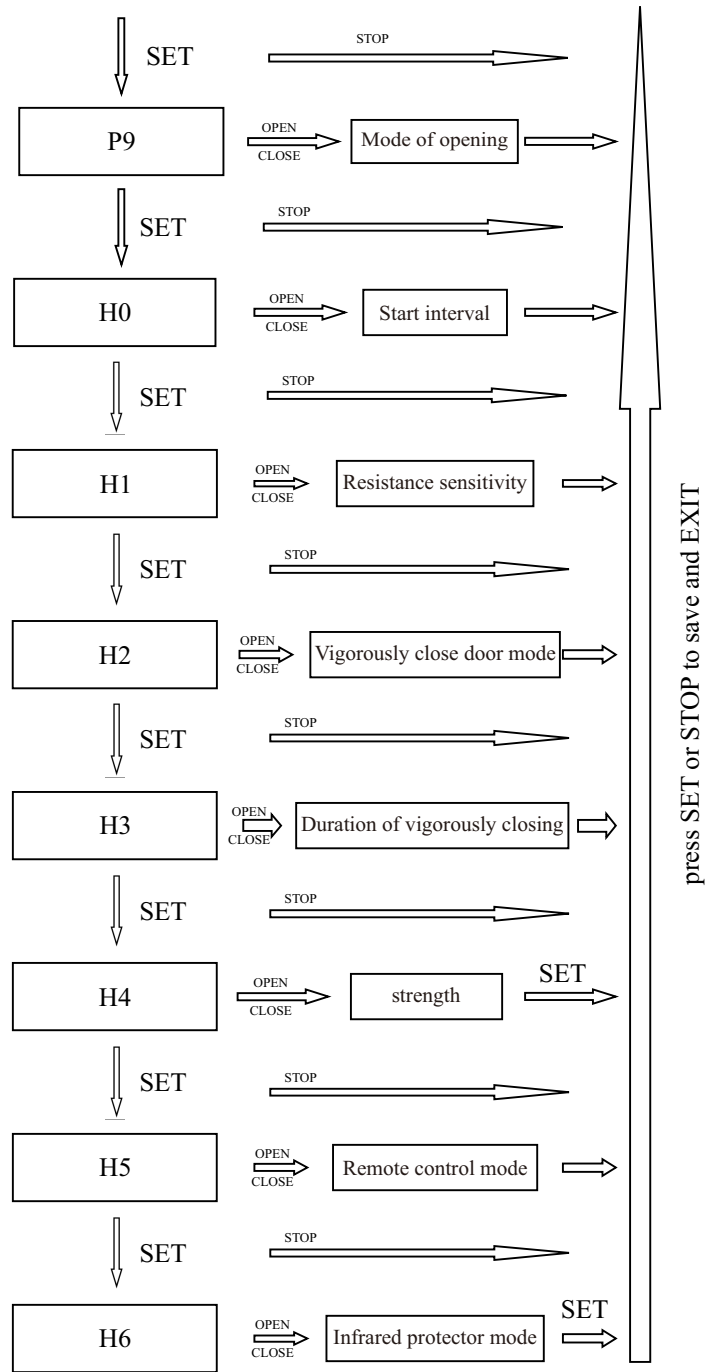

## 8. Trouble shooting

trouble	Trouble shooting
All LED indicators are off after power on.	<ul style="list-style-type: none"> <li>• Check the terminal wiring.</li> <li>• Check the power-on switch.</li> <li>• Check the fuse.</li> <li>• Measure the transformer's input and output.</li> <li>• Check the power chip on the control board.</li> </ul>
Door opening and closing are inconsistent with control mode.	<ul style="list-style-type: none"> <li>• Check the dip-switch 3.</li> </ul>
Transmitter doesn't work.	<ul style="list-style-type: none"> <li>• Change the battery.</li> <li>• Re-code.</li> <li>• Code another new transmitter.</li> <li>• After confirming the transmitter is normal, check whether the receiver on the control board works well. If not, change a new receiver.</li> </ul>
Motor doesn't work	<ul style="list-style-type: none"> <li>• Check and rewire the terminals.</li> <li>• Change a new motor and test whether the control board works well.</li> <li>• Change a new control board and test whether the motor works well.</li> </ul>
The Master and the Slave openers can not communicate	<ul style="list-style-type: none"> <li>• Check the communication wiring.</li> <li>• Check the dip-switch 1 and 2 setting correct.</li> <li>• Change control boards.</li> </ul>
Unable to set parameters	<ul style="list-style-type: none"> <li>• Check if the transmitter is coded.</li> <li>• Check if the coded transmitter works normally.</li> <li>• Check the dip-switch 2.</li> </ul>
Unable to set Limits by self-learning	<ul style="list-style-type: none"> <li>• Check the communication wiring.</li> <li>• Check whether the Master and the Slave openers set normally.</li> <li>• Change control boards.</li> </ul>



